

1. T7 skal monteres EFTER suppleringsvarme. Evt. i kanal.
2. T10 kan monteres i et repræsentativt udsugningsamatur i opholdsrum
3. Komponenter med stiplede forbindelser er tilbehør
4. Eksterne komponenter er ikke Nilan leverance
5. Optionsprint er tilbehør til CTS602

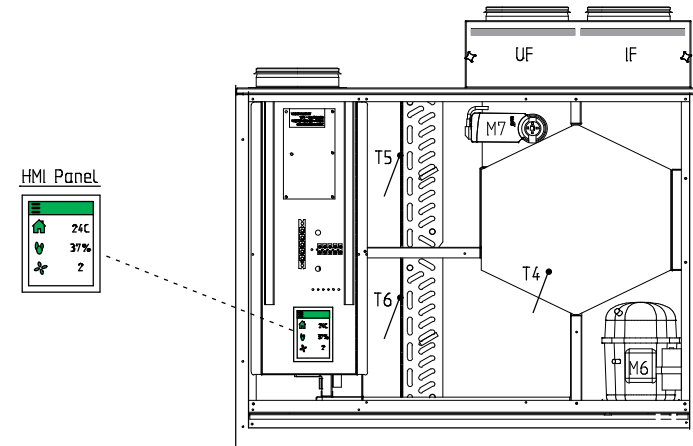
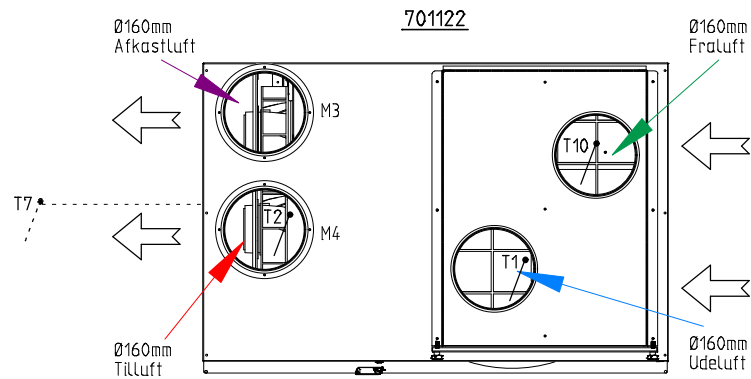

NILAN A/S
 Nilanvej 2
 DK-8722 Hedensted
 Tlf. +4576752500 <http://www.nilan.dk>
 Fax +4576752525 Email: nilan@nilan.dk

Combi 302 Top Polar XL
 CTS602 Styling, HMI-panel
 Varenr. 701122

Principdiagram / Flowdiagram

Ordrenr.

Revision 1.06

Initialer MD

Dato 29/09-2021

Nationalitet DK / N / S / SF

Side 1

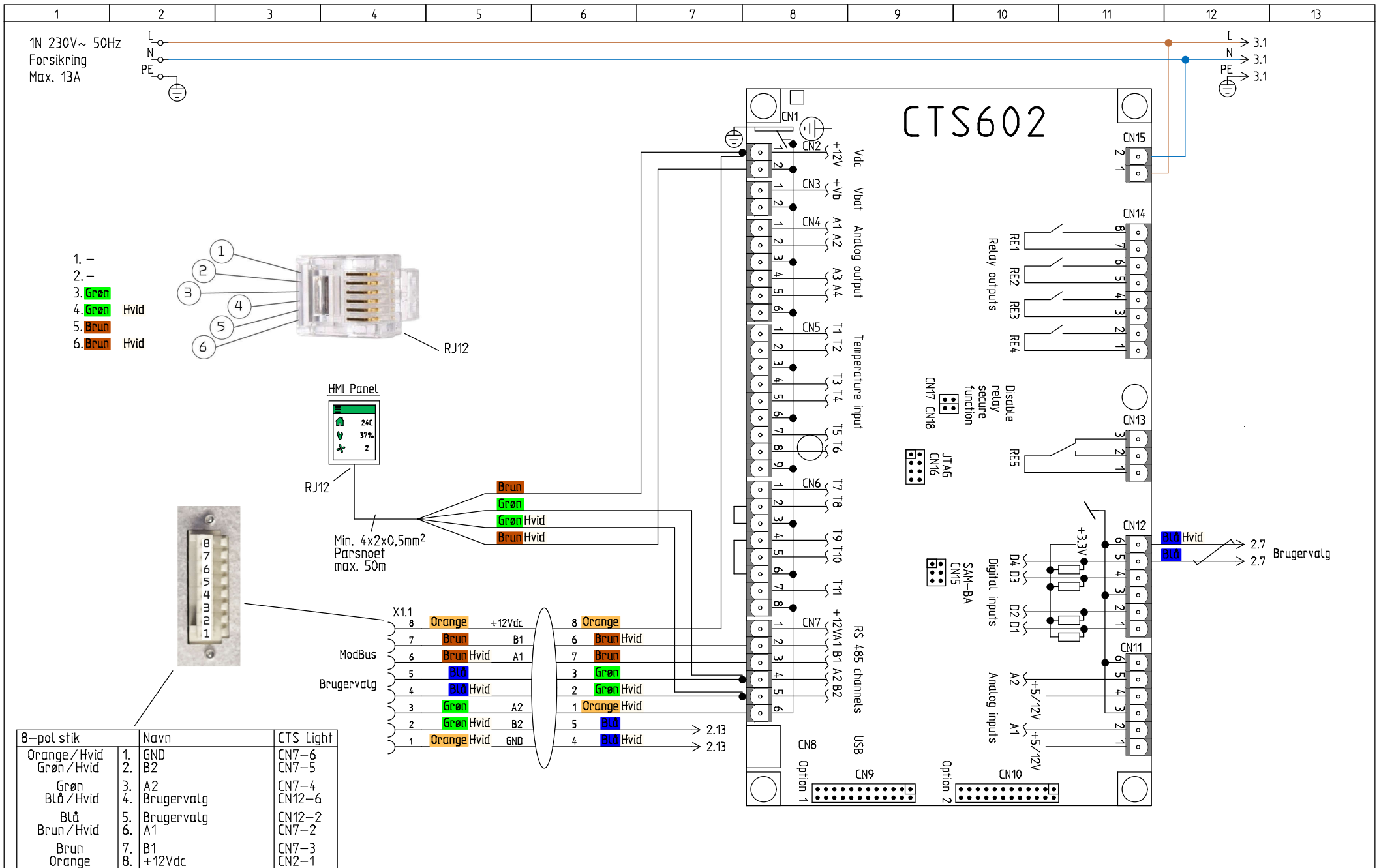

8-pol stik	Navn	CTS Light
Orange / Hvid	1. GND	CN7-6
Grøn / Hvid	2. B2	CN7-5
Grøn	3. A2	CN7-4
Blå / Hvid	4. Brugervalg	CN12-6
Blå	5. Brugervalg	CN12-2
Brun / Hvid	6. A1	CN7-2
Brun	7. B1	CN7-3
Orange	8. +12Vdc	CN2-1



NILAN A/S
 Nilanvej 2
 DK-8722 Hedensted
 Tlf. +4576752500
 Fax +4576752525
<http://www.nilan.dk>
 Email : nilan@nilan.dk

Combi 302 Top Polar XL
 CTS602 Styling, HMI-panel
 Varenr. 701122

CTS602 Styling

Ordrenr.

Revision 1.06

Initialer MD

Dato 29/09-2021

Nationalitet DK / N / S / SF

Side 2

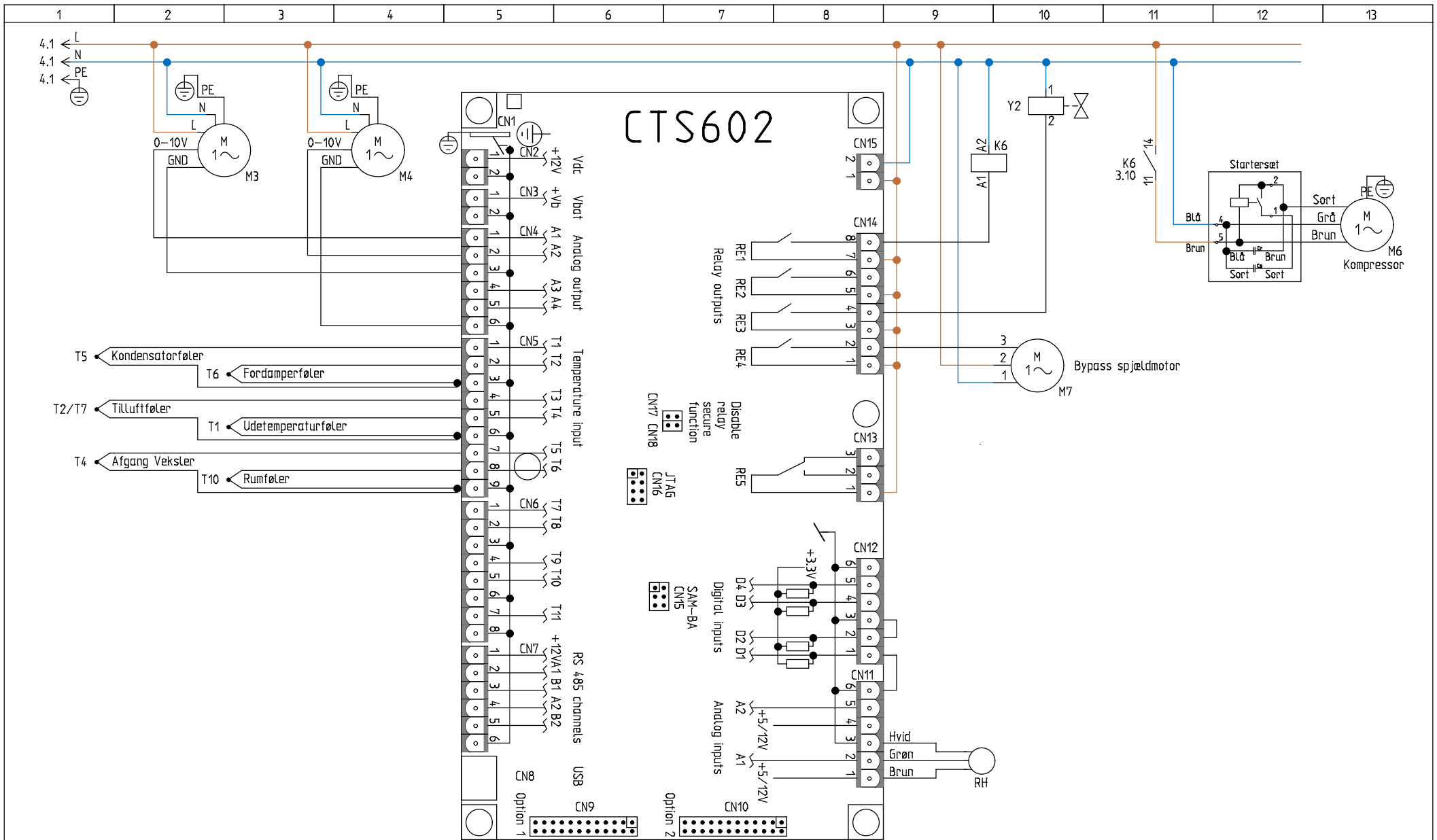

NILAN A/S
 Nilanvej 2
 DK-8722 Hedensted
 Tlf. +4576752500 <http://www.nilan.dk>
 Fax +4576752525 Email: nilan@nilan.dk

Combi 302 Top Polar XL
 CTS602 Styling, HMI-panel
 Varenr. 701122

CTS602 Styling

Ordrenr.	Revision	Initialer
	1.06	MD
Dato	Nationalitet	Side
29/09-2021	DK / N / S / SF	3

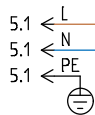

Frostsikring

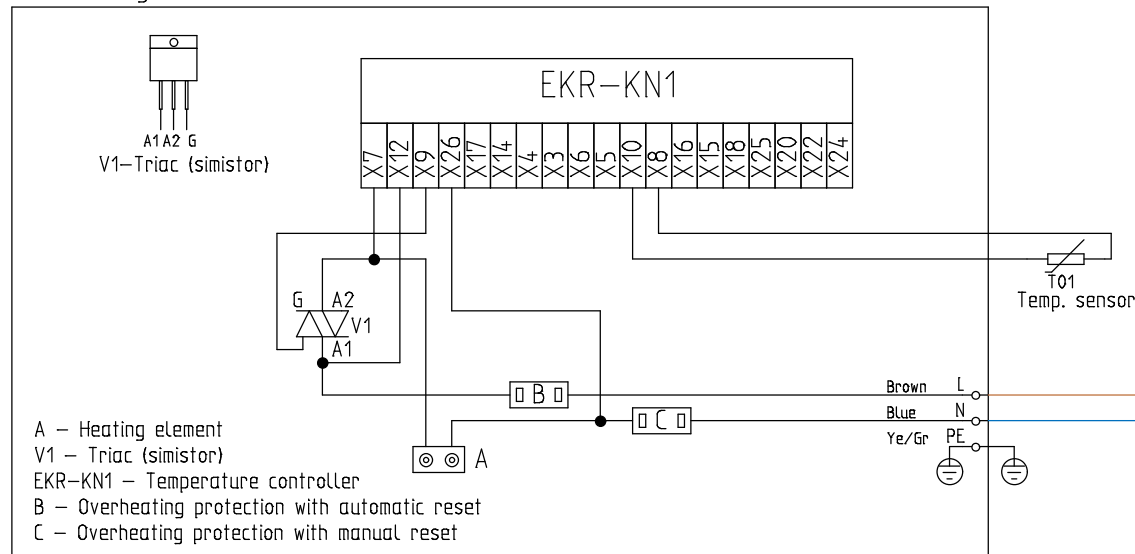

NILAN A/S
 Nilanvej 2
 DK-8722 Hedensted
 Tlf. +4576752500 <http://www.nilan.dk>
 Fax +4576752525 Email : nilan@nilan.dk

Combi 302 Top Polar XL
 CTS602 Styling, HMI-panel
 Varenr. 701122

Frostsikring

Ordrenr.	Revision 1.06	Initialer MD
Dato 29/09-2021	Nationalitet DK / N / S / SF	Side 4

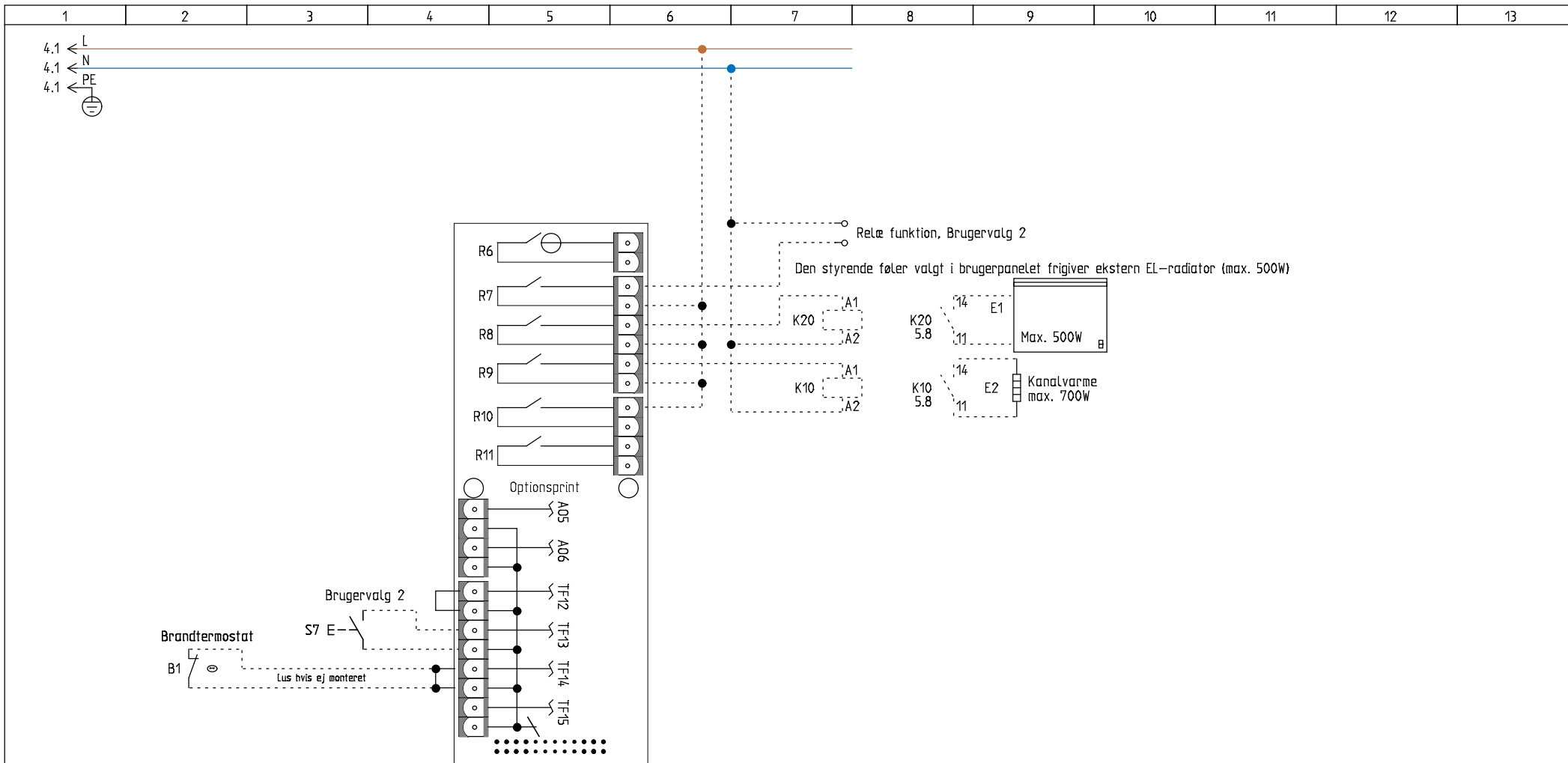

NILAN A/S
 Nilanvej 2
 DK-8722 Hedensted
 Tlf. +4576752500 <http://www.nilan.dk>
 Fax +4576752525 Email : nilan@nilan.dk

Combi 302 Top Polar XL
 CTS602 Styling, HMI-panel
 Varenr. 701122

Optionsprint

Ordrenr.

Revision 1.06

Initialer MD

Dato 29/09-2021

Nationalitet DK / N / S / SF

Side 5

CTS602

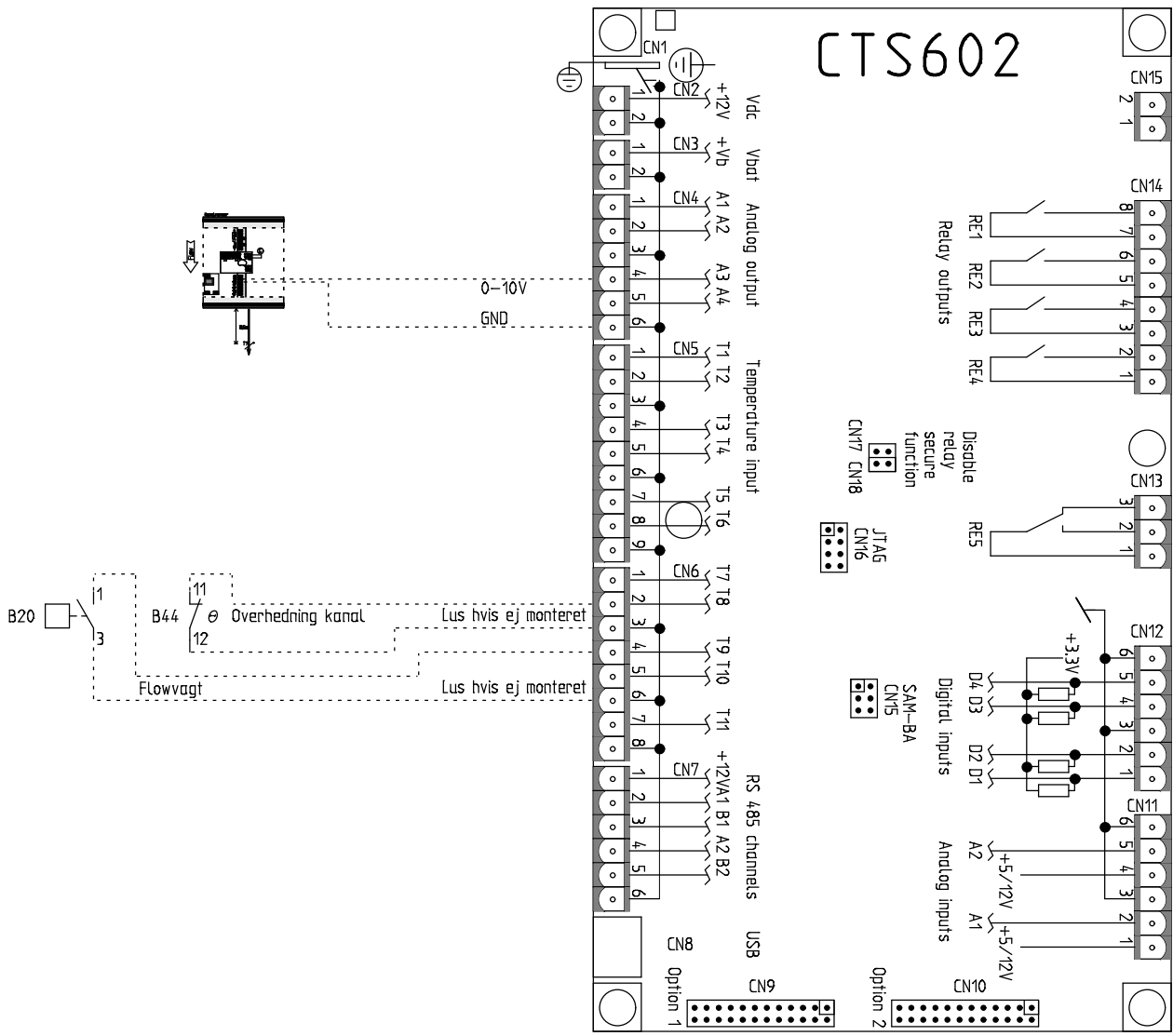

NILAN A/S
 Nilanvej 2
 DK-8722 Hedensted
 Tlf. +4576752500 <http://www.nilan.dk>
 Fax +4576752525 Email : nilan@nilan.dk

Combi 302 Top Polar XL
 CTS602 Styling, HMI-panel
 Varenr. 701122

Tilbehør

Ordrenr.	Revision 1.06	Initialer MD
Dato 29/09-2021	Nationalitet DK / N / S / SF	Side 6

Produktliste

Produkt	Type	Beskrivelse	Dokumenttype	Side	Strømvej
B1	EGO 55.33519.020 70–5°C, #15441	Brandtermostat Tilluft (Tilbehør)	Kredsskema	5	2
B20	Huba 20–300Pa, #3635	Flowvagt (Tilbehør)	Kredsskema	6	3
Cr	10µF, #1015	Driftskondensator	Kredsskema	3	12
Cs	80µF, #1015	Startkondensator	Kredsskema	3	12
E1	EL-varme Max. 500W	Ekstern rumvarme (Ej Nilan leverance)	Kredsskema	5	9
E2	Varmelegeme Max 700W	Kanalvarme (Tilbehør)	Kredsskema	5	9
IF	VP-Filter, #39167	Tilluft filter	Kredsskema	1	12
K6	Relæ 1C/0 16A 230VAC, #23470	Relæ Kompressor	Kredsskema	3	10
K10	Telemecanique RSB1A120P7S 230V, #23466	Relæ Kanalvarme	Kredsskema	5	8
K20	Telemecanique RSB1A120P7S 230V, #23466	Relæ EL-Radiator	Kredsskema	5	8
M3	R3G190–RD45–25 0,17kW 230V~, #41294	Frøluftmotor	Kredsskema	3	3
M4	R3G190–RD45–25 0,17kW 230V~, #41294	Tilluftmotor	Kredsskema	3	4
M6	Danfoss SC15GHH 220–240V~ 60Hz, #1015	Kompressor	Kredsskema	3	13
M7	Belimo CM230–F–L, #36463	Bypass spjældmotor	Kredsskema	3	10
Print	#239935	Optionsprint	Kredsskema	5	5
RH	#23997	Fugtføler	Kredsskema	3	9
S7	Kontakt	Kontakt for brugervalg 2 (Ej Nilan leverance)	Kredsskema	5	4
T01	NTC-føler JM103C1R1, #23995	Brugsvandsføler (Top)	Kredsskema	4	10
T1	NTC-føler JM103C1R1, #23995	Udetemperaturføler	Kredsskema	3	3
T2/T7	NTC-føler JM103C1R1, #23995	Tilluftføler	Kredsskema	3	2
T4	NTC-føler JM103C1R1, #239961	Afgang Vekster	Kredsskema	3	2
T5	NTC-føler JM103C1R1, #23995	Kondensatorføler	Kredsskema	3	2
T6	NTC-føler JM103C1R1, #239961	Fordamperføler	Kredsskema	3	3
T10	NTC-føler JM103C1R1, #23995	Rumføler	Kredsskema	3	3
UF	VP-Filter, #39167	Frøluft filter	Kredsskema	1	11
X1.1			Kredsskema	2	5
Y2	RV101A23AZ, #16424	4-vejsventil	Kredsskema	3	10



Combi 302 Top Polar XL
 CTS602 Styring, HMI-panel
 Varenr. 701122

Projekt	701122 V1-06 210929		Antal sider	1
Dato	29-09-2021	Land	DK / N / S / SF	Næste side
				Side
				1